

**Operational Mode**

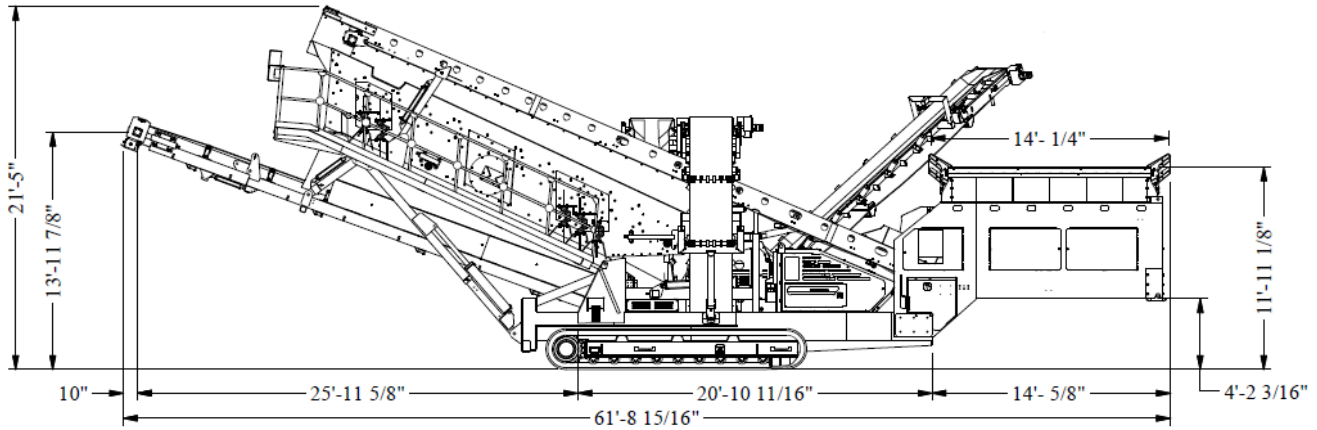

**Transportation Mode**

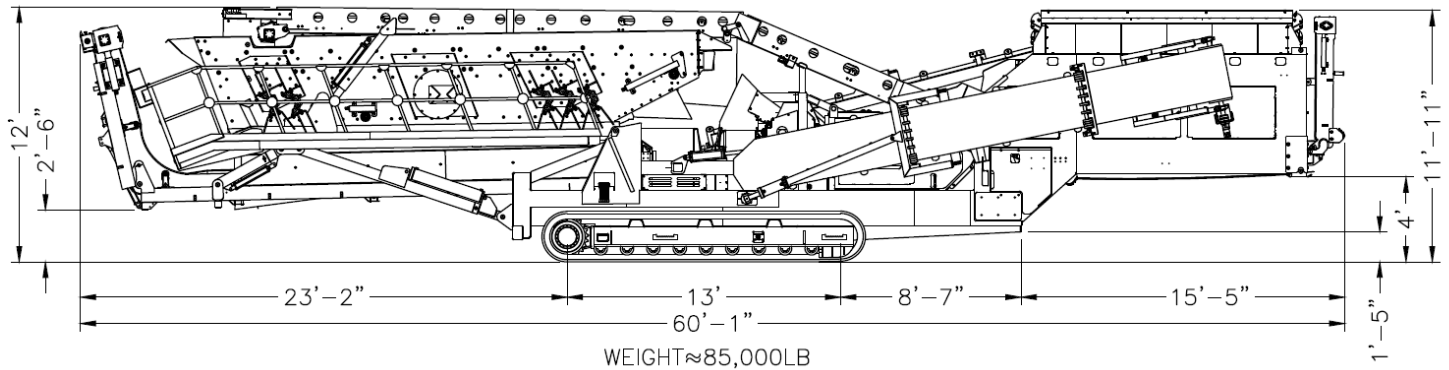

**DELIVERY CONVEYOR**

- One (1) 39' x 48" conveyor with hydraulic variable speed (350 FPM); hydraulic raise
- Full-length skirtboards
- 12" self-cleaning wing pulley
- Belting is 3-330-3-1; 1/2" cleat

**SIDE CONVEYORS**

- Two (2) 29' x 30" swing out conveyors
- Hydraulic variable speed (0-350 FPM)
- Folds for transport
- Belting is 2-220-3-1; 1/2" cleat
- Receiving hopper for both conveyors

**FINES CONVEYOR**

- One (1) 29'10" x 48" conveyor with hydraulic variable speed (350 FPM)
- Folds for transport
- 12" self-cleaning wing pulley
- Belting is 220 PIW, 1/8 x 1/16 cover

**CROSS CONVEYOR**

- One (1) 6' x 24" conveyor with hydraulic variable speed (350 FPM)
- Formed plate; stationary within frame
- 220 PIW; 1/8 x 1/16 cover, 1/2" cleat

**NOTE: Specifications are subject to change without notice.**

## OVERS CONVEYOR

- One (1) 31' x 24" conveyor with hydraulic variable speed (350 FPM)
- Folds for transport
- Rubber lagged head pulley
- 220 PIW; 1/8 x 1/16 cover, 1/2" cleat

## HOPPER

- 10 cubic yard head capacity
- Heavy-duty grizzly with 6" opening
- Hydraulic dump

## FEEDER

- One (1) 13' x 48" conveyor with hydraulic variable speed (0-60 FPM)
- Rubber lagged head pulley
- 330 PIW, 3/16" x 1/16" cover

## CHASSIS

- 20" formed plate
- Tracks w wireless remote control

## POWER SYSTEM

- 173 HP Tier IV C6.6 Cat diesel engine
- Engine mounted hydraulic pumps to operate all plant functions
- NEMA-4 rated instrument panel
- Emergency stops

## VIBRATING SCREEN

- One (1) 3620K triple deck Kolberg® screen
- 6' x 20' top deck and middle deck
- 6' x 18' bottom deck
- Decks driven by 900 RPM vibrating mechanism mounted on screen
- Adjustable amplitude with add on weights

- Hydraulic controls for variable angle operation
- Top and bottom deck discharge chutes
- Aggregate spreader; Fixed access ladder with wrap around walkway
- Less screen cloth (top/ middle deck side tension; bottom deck rotary end tension)

## PLANT CAPACITY

- Up to 700TPH of 8" feed material (tonnages will vary with conditions)

## PAINT

- One primer coat, finish coat of KPI Beige

## SERVICE CAPACITY

- 140 gal. fuel tank
- 150 gallon hydraulic reservoir with return filters

## OPTIONS

- Standard steel screen cloth for FT3620
- Remote control grizzly
- Wings for funneling feed material onto feed hopper
- Hammermill shredder
- Ball tray for bottom deck module
- Rinser to include spray bars and collection flume
- Blending gates
- CONSULT FACTORY FOR ADDITIONAL OPTIONS

## PHYSICAL OPERATION CHARACTERISTICS

- Overall Length.....61'9"/18.87m
- Travel Length.....58'11"/17.95m
- Operating Height.....21'5"/6.55m
- Travel Height.....12'/3.66m
- Operating Width.....49'11"/15.21m
- Travel Width.....11'11' /3.59m
- Unit Weight.....85,000lbs/38,555 kg



2704 West LeFevre Road  
Sterling, IL 61081

Phone: (815) 626-6374

FAX: (815) 626-6430

[mail@kpijci.com](mailto:mail@kpijci.com)

[www.kpijci.com](http://www.kpijci.com)

**NOTE: Specifications are subject to change without notice.**

Because Astec Mobile Screens may use in its catalog & literature, field photographs of its products which may have been modified by the owners, products furnished by Astec Mobile Screens may not necessarily be as illustrated therein. Also continuous design progress makes it necessary that specifications be subject to change without notice. All sales of the products of Astec Mobile Screens are subject to the provisions of its standard warranty. Astec Mobile Screens does not warrant or represent that its product meet and federal, state, or local statutes, codes, ordinances, rules, standards or other regulations, including OSHA and MSHA, covering safety, pollution, electrical wiring, etc. Compliance with these statutes and regulations is the responsibility of the user and will be dependent upon the areas and the use to which the product is put by the user. In some photographs, guards may have been removed for illustrative purposes only. This equipment should not be operated without all guards attached in their normal position. Placement of guards and other safety equipment is often dependent upon the area and the use to which the product is put. A safety study should be made by the user of the application, and, if required additional guards, warning signs and other safety devices should be installed by the user, wherever appropriate before operating the products.